

PowerKit Engine

4M06 Series

General Specifications

Bore x Stroke	89 x 92 mm
Displacement	2.3 L
N° of Cylinders	4
Cylinders Arrangement	In line
Fuel System	Mechanical Pump / Common Rail
Governor (Gov.)	Electronic / ECU
Aspiration (Asp.)	NA / T / T/A-A

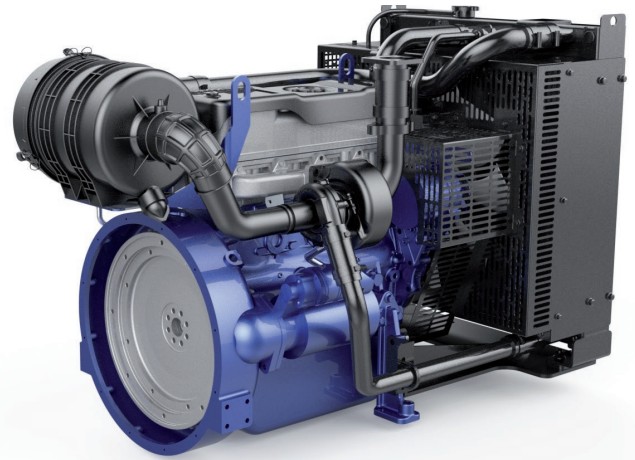

Diesel Engine	Speed Rpm	Gross Engine Output		Typical Generator Output				Asp.	Gov.
		Prime Power PRP kWm	Standby Power ESP kWm	Prime Power PRP		Standby Power ESP			
				kWe	kVA	kWe	kVA		
4M06G20/5	1500	18	20	15	18	16	20	NA	Elec
4M06G25/5	1500	23	25	18	23	20	25	NA	Elec
4M06G35/5	1500	30	33	26	32	28	35	T	Elec
4M06G44/5	1500	37	41	32	40	35	44	T	Elec
4M06G50/5	1500	44	48	36	45	40	50	T/A-A	Elec
4M06G55/5	1500	48	53	40	50	44	55	T/A-A	ECU
4M06G20/6	1800	23	25	18	23	20	25	NA	Elec
4M06G25/6	1800	27	30	23	29	25	32	NA	Elec
4M06G33/6	1800	37	41	30	38	33	42	T	Elec
4M06G41/6	1800	43	47	37	47	41	51	T	Elec
4M06G50/6	1800	53	58	45	56	50	63	T/A-A	Elec
4M06G55/6	1800	58	63	50	63	55	69	T/A-A	ECU

Aspiration : NA = Naturally Aspirated, T = Turbocharged, T/A-A = Turbocharged & Air-to-Air Aftercooled

Standard Equipment

Engine and block

- Cast iron gantry type structure block
- One-piece forged crankshaft
- Separate cast iron cylinder heads and wet liners
- Aluminum alloy pistons with oil cooling gallery

Cooling system

- Radiator and hoses supplied directly mounted on the engine
- Thermostatically-controlled system with belt driven coolant pump and pusher fan

Lubrication system

- Flat bottom large capacity oil pan
- Spin-on full-flow lube oil filter

Fuel system

- P type fuel injection pump and injector for higher inject pressure, for engines with electronic governor
- High pressure Common Rail injection system, for engines with ECU Fine filter

Air intake and exhaust system

- Special rear mounted air filter with restriction indicator
- Exhaust manifold shield for heat isolating

Electrical system

- 12 Vdc electric starter motor and battery charging alternator
- LOP + HWT sensors

Flywheel and housing

- SAE 4 flywheel housing and 7.5" flywheel, for engines 4M06G20/5 & 25/5 and 4M06G20/6 & 25/6
- SAE 3 flywheel housing and 11.5" flywheel, for other engines

Ratings definitions

Emergency Standby Power (ESP)

Emergency Standby Power is the maximum power available for a varying load for the duration of a main power network failure. The average load factor over 24 hours of operation should not exceed 70% of the engine's ESP power rating. Typical operational hours of the engine is 200 hours per year, with a maximum usage of 500 hours per year. This includes an annual maximum of 25 hours per year at the ESP power rating. No overload capability is allowed. The engine is not to be used for sustained utility paralleling applications.

Unlimited Prime Rated Power (PRP)

Prime Power is the maximum power available for unlimited hours of usage in a variable load application. The average load factor should not exceed 70% of the engine's PRP power rating during any 24 hour period. An overload capability of 10% is available, however, this is limited to 1 hour within every 12 hour period.

Continuous Power (COP)

Continuous Power is the maximum power available for an unlimited period of use at a constant load factor. No overload capability is allowed.

1) All ratings are based on operating conditions under ISO 8528-1, ISO 3046, DIN6271. Performance tolerance of $\pm 5\%$.

2) Test conditions: 100 kPa, 25°C air inlet temperature, relative humidity of 30%, with fuel density 0.84 kg/L. Derating may be required for conditions outside these; please contact the factory for details.

3) Power output curves are based on the engine operating with fuel system, water pump and lubricating oil pump; not included are battery charging alternator, fan and optional equipment.

Dimensions and dry weight (mm / kg)

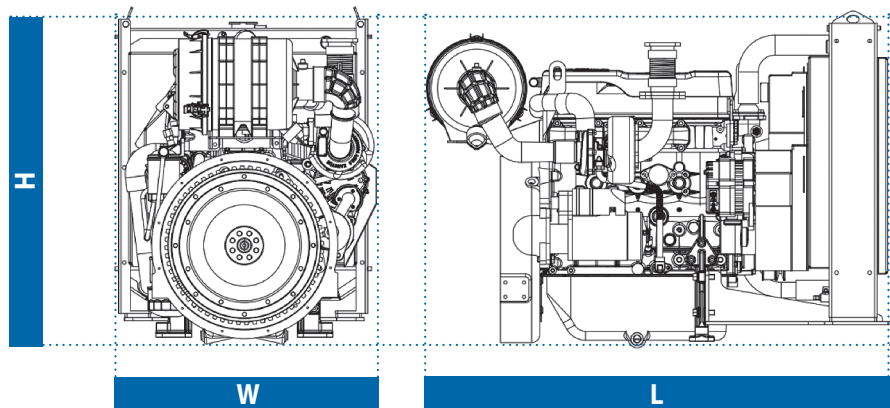

Diesel Engine	Speed Rpm	Dimensions and dry weights including radiator			
		L mm	W mm	H mm	Weight Kg.
4M06620/5	1500	1064	627	786	277
4M06625/5	1500	1064	627	786	277
4M06635/5	1500	1120	627	786	280
4M06644/5	1500	1120	627	786	280
4M06650/5	1500	1184	646	786	285
4M06655/5	1500	1184	646	786	285
4M06620/6	1800	1064	627	786	277
4M06625/6	1800	1064	627	786	277
4M06633/6	1800	1120	627	786	280
4M06641/6	1800	1120	627	786	280
4M06650/6	1800	1184	646	786	285
4M06655/6	1800	1184	646	786	285