



INHERITING FROM THE WORLD'S
LEADING TECHNOLOGY

1004G POWER PACK IN-LINE PUMP

40 kWm 1500 rev/min
44 kWm 1800 rev/min
GENSET POWER

High Power Density

Power output and torque per liter are superior to normal level with optimized structure strengthening.

Low Fuel Consumption

The excellent combustion system can reduce fuel consumption, emission and noise, meanwhile increase engine power output.

Easy Maintenance

All routine service items are situated on the right hand side of engine allowing easy maintenance and minimum machine downtime.

Durability & Reliability

Start normally at -10°C without preheated device, start smoothly at -25°C through flame glow plug cold start aid.
Maximum cooling efficiency is provided by a gear driven water pump and independent fan drive.
Leak free operation is ensured by Viton crankshaft seals and sophisticated controlled swell joints, giving protection in the toughest conditions.

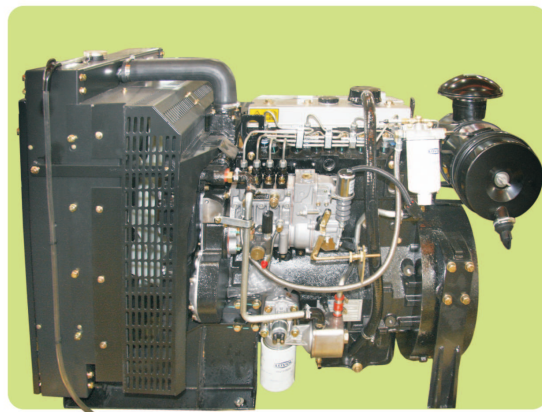

Engine Speed (rev/min)	Type of Operation	Typical Generator Output (Net)		Engine Power			
				Gross		Net	
		kVA	kW	kWm	bh	kWm	bh
1500	prime power	44.4	35.5	42	56.3	40	53.6
	standby power	48.4	38.7	46	61.6	44	59
1800	prime power	48.7	39	47	63	44	59
	standby power	53.3	42.6	51	68.3	48	64.3

Rating Base: ISO 8528, GB/T2820
Lubricating oil: API CF



INHERITING FROM THE WORLD'S
LEADING TECHNOLOGY

Standard Specification

Air inlet
Mounted air filter

Fuel system
In-line fuel injection pump
Spin-on full flow fuel filter and pre-filter

Lubrication system
Flat bottomed aluminum sump
Spin-on full flow oil filter
Oil cooler

Cooling system
Thermostat controlled cooling system
with gear driven water pump
Radiator
20" belt-driven pusher fan and guards

Electrical system
12 volt starter motor and alternator
Oil pressure and water temperature
switch & sensor
12 volt shut down solenoid

Flywheel and housing
High inertia flywheel, size : 10/11_{1/2}
SAE3 flywheel housing

Mountings
Front engine mounting bracket

Optional Equipment
24 volt alternator
24 volt starter motor

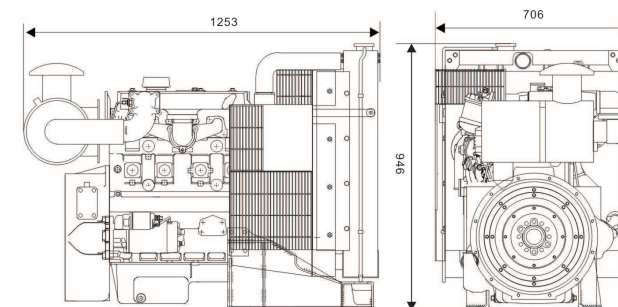

General Data

Cylinder number	4
Cylinder arrangement	Vertical, in-line
Bore×stroke	100 mm×127 mm
Displacement	3.99 liters
Induction	Naturally aspirated
Cycle	4-stroke
Combustion system	Direct injection
Compression ratio	16.5:1
Direction of Rotation	Clockwise viewed from fan
Lub. System Capacity	8.5 liters
Coolant capacity (inc. radiator)	17.6 liters
Length	1253mm
Width	706 mm
Height	946 mm
net weight	540 kg

Final weight and dimensions will depend on final specification.



TIANJIN LOVOL ENGINES CO., LTD.
77 Gaoxin Avenue, Beichen Hi-tech Industrial
park, Beichen district, Tianjin.
Tel: +86(0)22 26899125/26996802
Fax: +86(0)22 86993260
Email: lovolengines@lovolengines.com
www.lovolengines.com

All information in this document is substantially
correct at the time of printing and may be altered
subsequently.

Distributed by